

EN

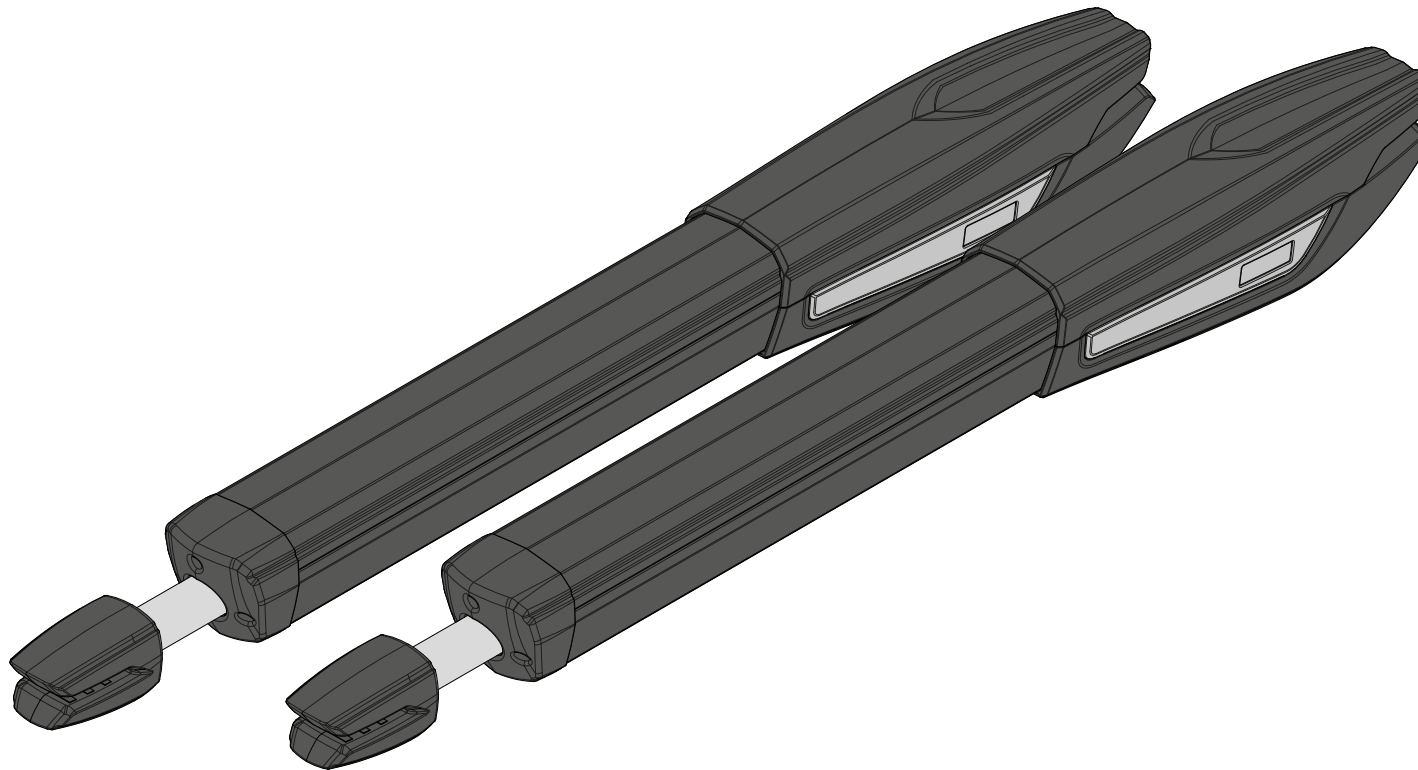

# JAG

USER'S AND INSTALLER'S MANUAL



**motorline**<sup>®</sup>  
PROFESSIONAL

V3.0  
REV. 12/2016

# 00. CONTENT

## INDEX

<b>01. SAFETY INSTRUCTIONS</b>	
STANDARDS TO FOLLOW	1B
<b>02. PACKAGE</b>	
INSIDE PACKAGE	2A
<b>03. OPERATOR</b>	
TECHNICAL SPECIFICATIONS	2B
UNLOCK MOTOR	3A
<b>04. INSTALLATION</b>	
VERTICAL INSTALLATION MEASURES	3B
HORIZONTAL INSTALLATION DIMENSIONS	4A
INSTALLATION STEPS	5A
MICROS ADJUSTMENT	6A
INSTALLATION MAP	7
<b>05. CONNECTION SCHEME</b>	
MOTOR A 230V/110V	8A
MOTOR A 24V	8A
<b>06. COMPONENTS TEST</b>	
MOTOR A 24V	8B
MOTOR A 230V/110V	9
<b>07. MAINTENANCE</b>	
MAINTENANCE	10
<b>08. TROUBLESHOOTING</b>	
FINAL CONSUMERS INSTRUCTIONS	11
INSTRUCTIONS FOR SPECIALIZED INSTALLERS	11

# 01. SAFETY INSTRUCTIONS

## STANDARDS TO FOLLOW

### ATTENTION:

#### Importance of the Manual:

- It is important for your safety that these instructions are followed.
- Keep these instructions in a safe place for future reference.

#### Responsibility:

- The **ELECTROCELOS S.A.** is not responsible for the improper use of the product, or other use than that for which it was designed.
- The **ELECTROCELOS S.A.** is not responsible if safety standards were not taken into account when installing the equipment, or for any deformation that may occur.
- The **ELECTROCELOS S.A.** is not responsible for insecurity and malfunction of the product when used with components that were not sold by the them.
- The **ELECTROCELOS S.A.** informs that, to guarantee greater compatibility and proper functioning, install only components MOTORLINE.

#### Mechanism use:

- This product was designed and manufactured strictly for the use indicated in this manual.
- This control board is not appropriate for inflammable or explosive environments.
- Any other use not expressly indicated may damage the product and / or can cause physical and property damages, and will void the warranty.
- Do not make any changes to the automation components and / or their accessories.
- Control board for indoor use with 110V/230V connection.
- Keep remote controls away from children, to prevent the automated system from being activated involuntarily.
- The customer shall not, under any circumstances, attempt to repair or tune the automatism. Must call qualified technician only.

#### To Installer:

- The installer must have certified professional knowledge at the level of mechanical assemblies in doors and gates and control board programming. He should also be able to perform electrical connections in compliance with all applicable regulations.
- The installer should inform the customer how to handle the product in an emergency and provide him the manual.

## 02. PACKAGE

### INSIDE PACKAGE

In the package you will find the following components:

- 01 • 02 swing operators
- 02 • 01 Control Board
- 03 • 02 remote controls (4 channels)
- 04 • 02 Front supports
- 05 • 02 Rear supports
- 06 • 02 Capacitors [12,5µF (230V) or 35µF (110V)]
- 07 • 01 Photocells
- 08 • 01 User's manual
- 09 • Release keys

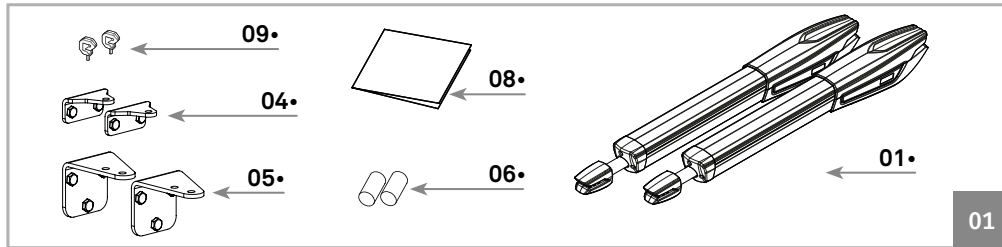

Electronic components in the kit:

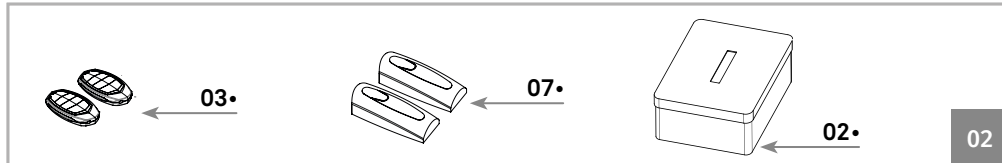

Kit Package:

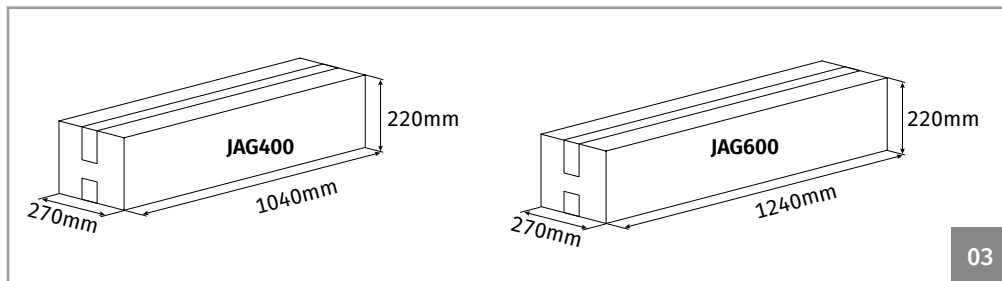

## 03. OPERATOR

### TECHNICAL SPECIFICATIONS

JAG specifications are as follow:

		JAG400	JAG600
• Power Supply	230V	AC 230V 50/60Hz	AC 230V 50/60Hz
	110V	AC 110V 50/60Hz	AC 110V 50/60Hz
	24V	DC 24V	DC 24V
• Power	230/110V	300W	300W
	24V	80W	80W
• Current	230V	1,3A	1,3A
	110V	2,5A	2,5A
	24V	3A	3A
• RPM	230/110V	1400 RPM	1400 RPM
	24V	1650 RPM	1650 RPM
• Noise level		<50dB	<50dB
• Force		2800N	2800N
• Operating temperatures		-25°C a 75°C	-25°C a 75°C
• Thermal protection		120°C	120°C
• Protection class		IP54	IP54
• Working frequency	230/110V	25%	25%
	24V	Intensive	Intensive
• Course		400mm	600mm
• Max leaf length		<5000mm	<6000mm
• Capacitor	230V	12,5µF	12,5µF
	110V	35µF	35µF

## 03. OPERATOR

### TECHNICAL SPECIFICATIONS

JAG 400 || 600 dimensions are the following:

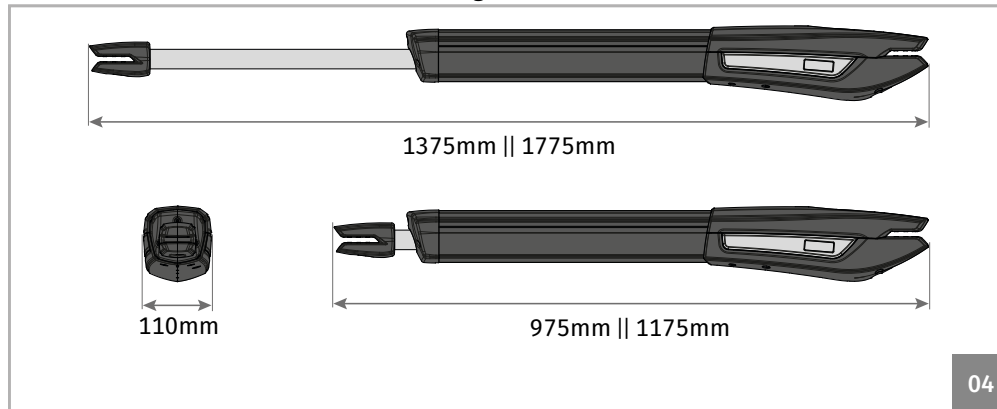

### LOCK/UNLOCK MOTOR

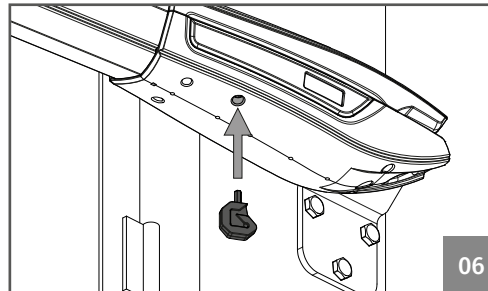
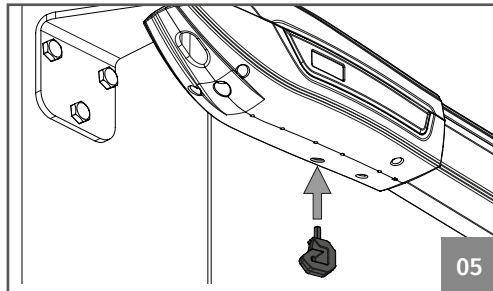

Place the unlocking key in the slot signed on image 05 (motor installed on the left) or 06 (motor installed on the right).

Turn the key to lock or unlock the motor.

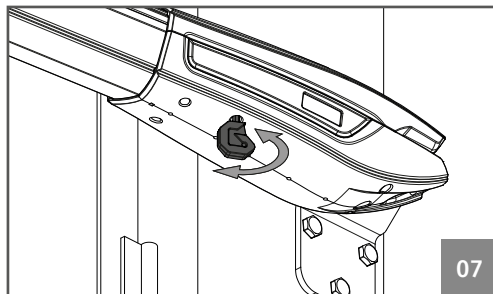

## 04. INSTALLATION

### VERTICAL INSTALLATION DIMENSIONS

Operator must be installed with a small inclination, to prevent water infiltration through the extension arm.

For this, the front support must be fixed to the gate with a height lower than the height of the rear support. See example below:

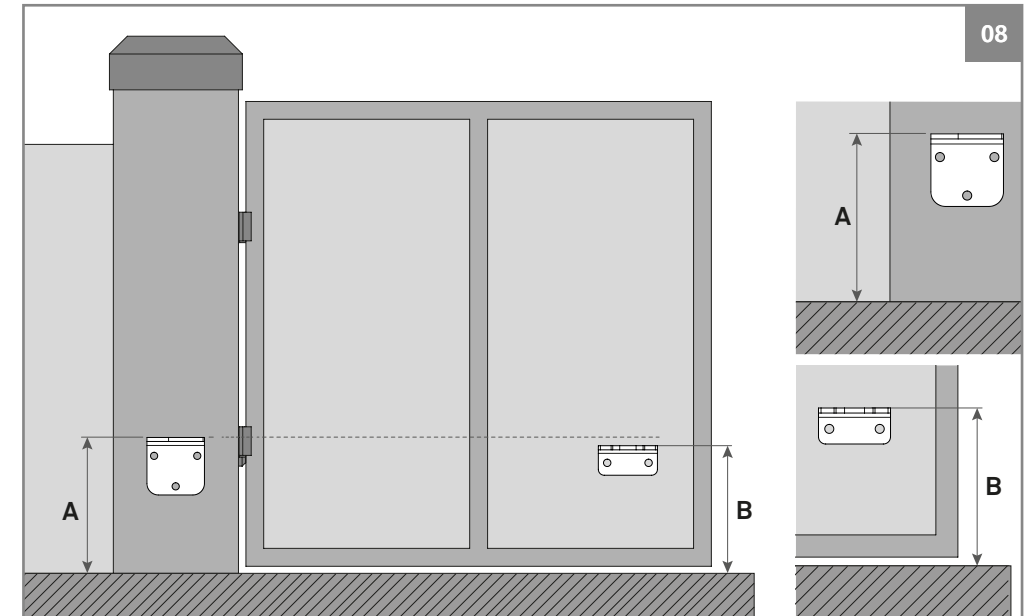

**Dimension A** • Vertical distance from the floor to the top of the rear support.

**Dimension B** • Vertical distance from the floor to the top of the front support.

A	?? mm	• Set <b>dimension A</b> (this can be any size of your choice).
B	A - 20mm	• After you set <b>dimension A</b> , subtract <b>20mm</b> to find <b>dimension B</b> .

#### Example:

- If the height of the rear bracket (dimension A) is set at 600 mm, then the height of the front bracket (dimension B) will be 580 mm (600mm-20mm).



**It is very important that these dimensions are respected! Only this way can be assured the correct functioning and durability of the operators!**  
It is also very important to have a levelled ground/terrain!

# 04. INSTALLATION

## HORIZONTAL INSTALLATION DIMENSIONS

On the Illustrated diagrams below and on the next page, are the horizontal dimensions for the installation of the automated system.

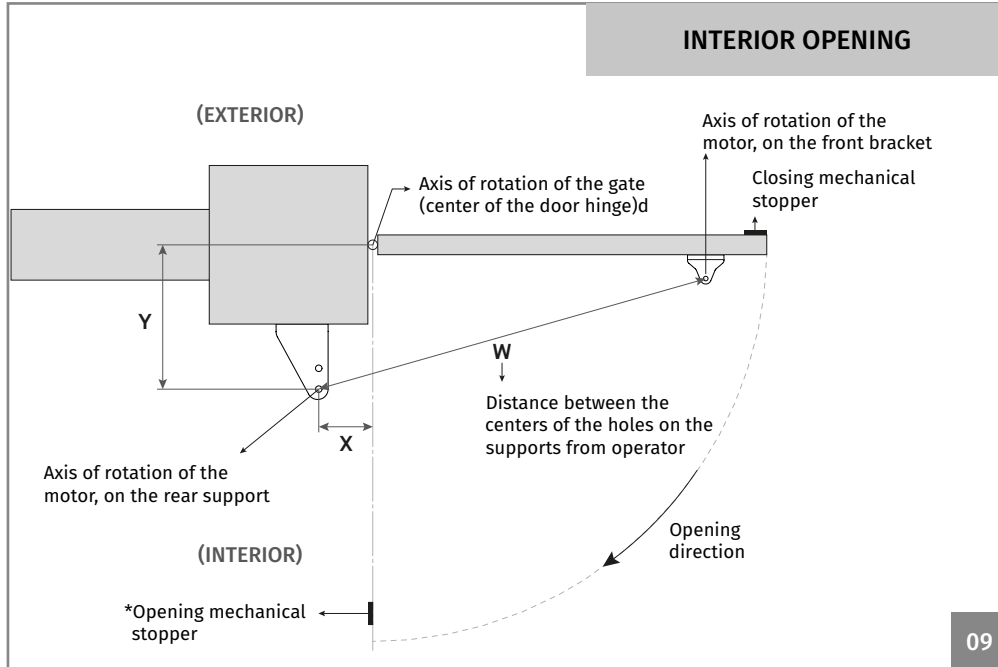

\* The installation of opening stopper is not mandatory.

	Opening angle	X	Y	W
• JAG 400	95°	120 a 180	120 a 180	1295-1300
	120°	160 a 180	120 a 140	1295-1300
• JAG 600	95°	120 a 350	120 a 200	1695-1700
	120°	200 a 280	120 a 200	1695-1700



**It is very important that these dimensions are respected!** Only this way can be assured the correct functioning and durability of the operators!

# 04. INSTALLATION

## HORIZONTAL INSTALLATION DIMENSIONS

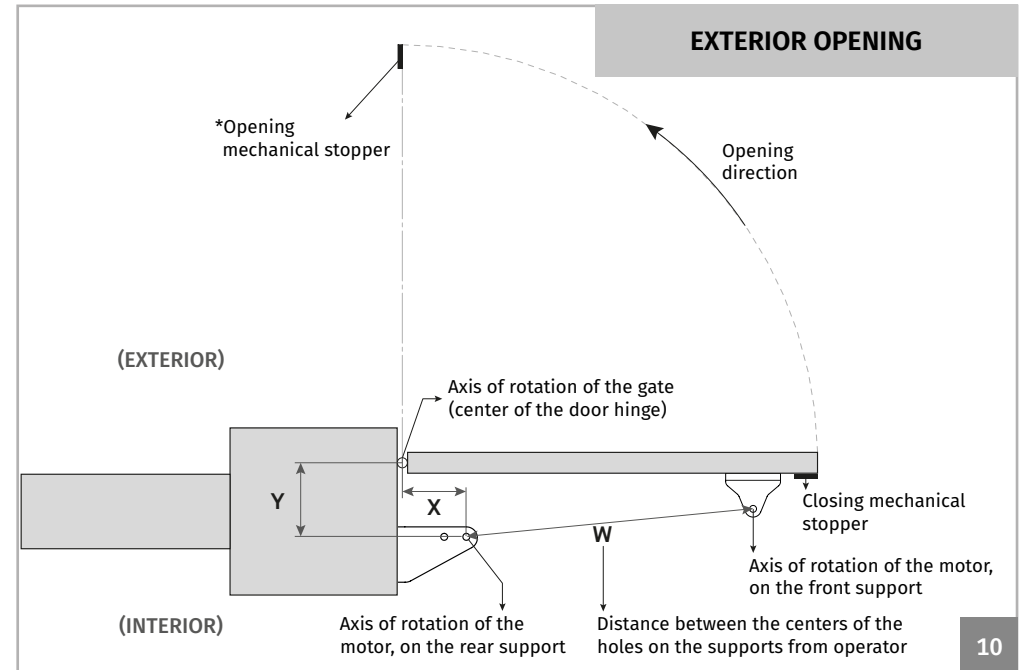

\* The installation of opening stopper is not mandatory.

	Opening angle	X	Y	W
• JAG 400	95°	160 a 200	120 a 180	895-900
• JAG 600	95°	160 a 300	120 a 280	895-900

### Legend:

**Dimension X - Horizontal distance** between hinge axis of the door and the rear axle of the motor.

**Dimension Y - Vertical distance** between hinge axis of the door and the rear axle of the motor.

**Dimension W - Distance** between axis of the motor brackets.

## 04. INSTALLATION

### INSTALLATION STEPS

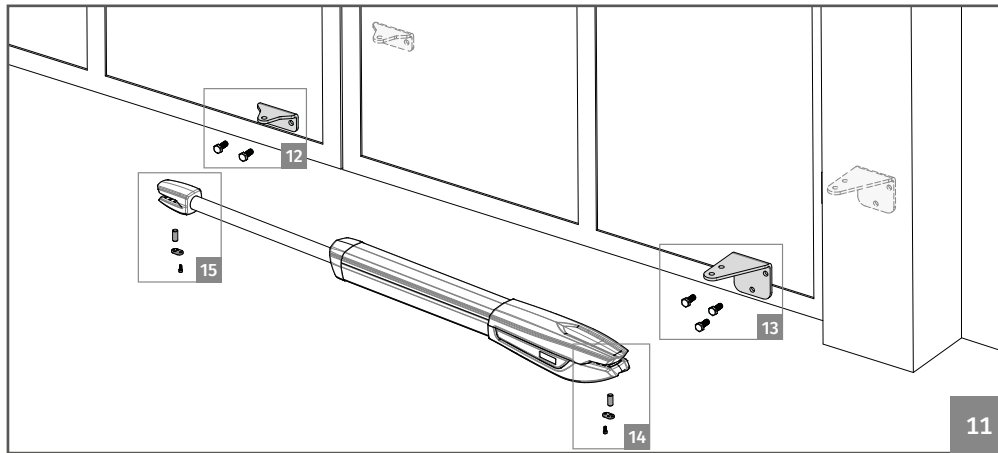

Pay attention to the installation dimensions mentioned on pages 03B, 04A and 04B!

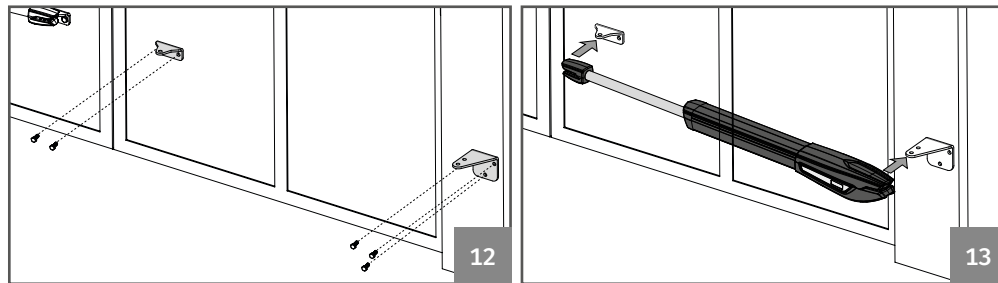

#### 01 • Fix the supports.

- The rear support must be fixed on the pillar or wall.
- The front support must be fixed on the gate. Respect the height and distance measures between the front and rear supports. It can be fixed by using screws with mechanical bushing or chemical welding process, because both provide an appropriate support.

#### 02 • Install the operator on the supports

- The operator must be placed on both supports the same time to avoid leaving the operator suspended by only one of the supports. To make the task easier, you should unlock the operator in order to be able to stretch/retract arm easily (see page 03B), to get the correct position for supports.

## 04. INSTALLATION

### INSTALLATION STEPS

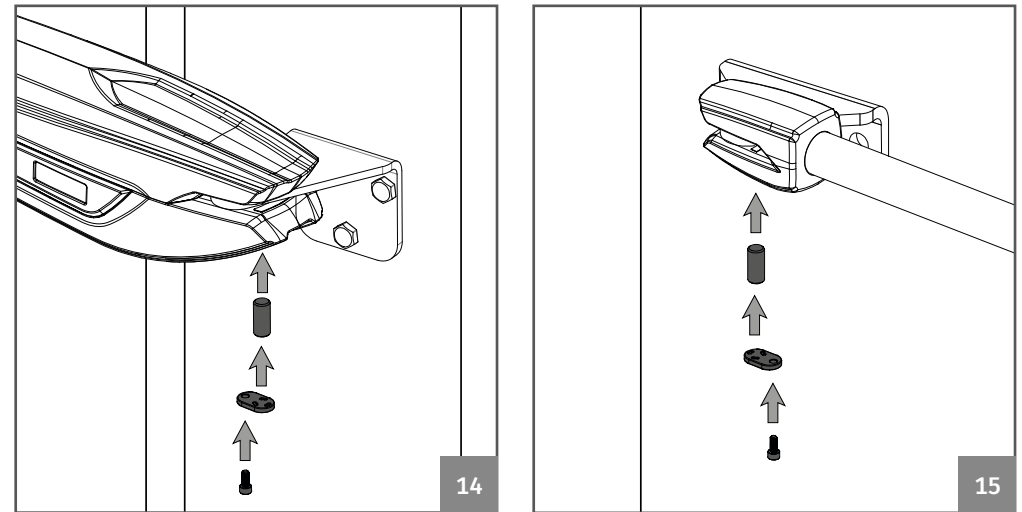

#### 03 • Test the movement.

- Install the pins removed earlier on each side with a small amount of lubricant for less friction.
- Unlock the motor and move the door manually to see if the door opens and closes uniformly and correctly, without any irregular friction during its entire movement. This will ensure that the motor is not subjected to problems during operation.

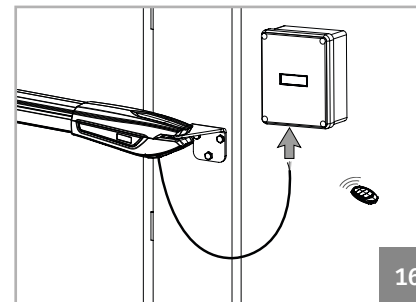

#### 04 • Connecting the motor to control board and configuring control devices.

- With the motor installed, connect it to control board for system configuration (see control board user manual). It is important to configure the desired control devices (remote controls, wall switch, etc.) and other additional components such as antenna, flashing light, key selector, among others.



**It is important to respect this installation order!**

Otherwise, it is not possible to ensure correct installation and the motors may not work properly!

## 04. INSTALLATION

### MICROS ADJUSTMENT

01 • Unlock the motor (see page 3A).

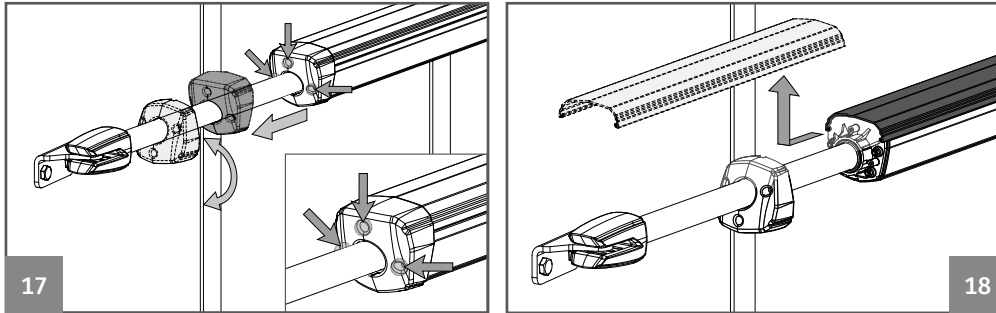

02 • Loosen the 3 front screws, remove the cover and the profile cover.

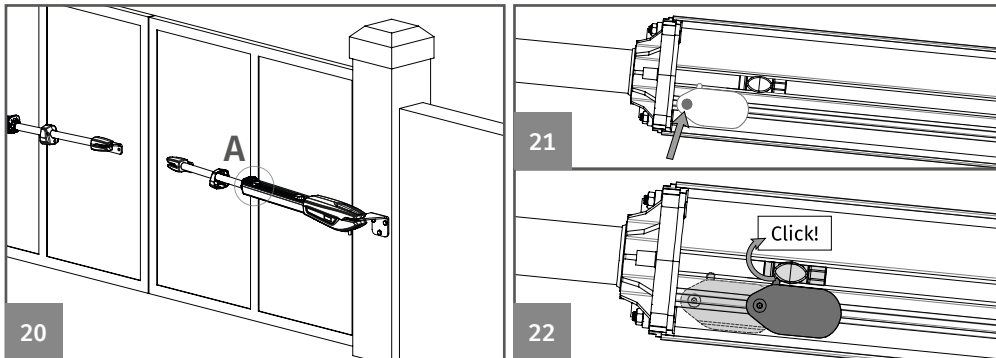
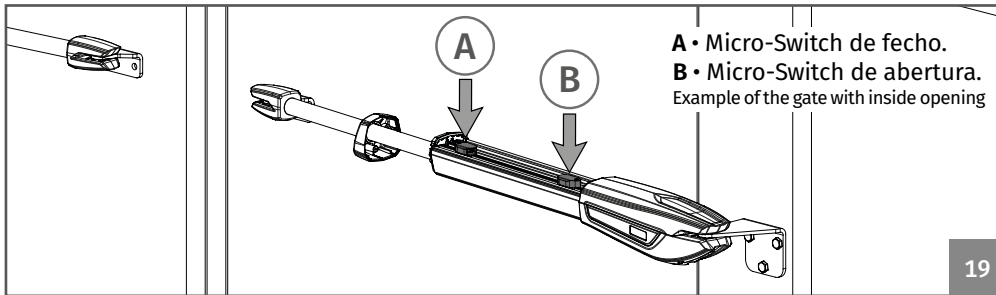

03 • Take the gate to the closed position.

04 • Loosen the screw shown in the image (21), so that it is possible to move the micro-switch in the profile.

05 • Adjust the closure micro-switch (A) until it makes "click" on the pressure piece. Tighten the screw to secure the micro in that position.

## 04. INSTALLATION

### MICROS ADJUSTMENT

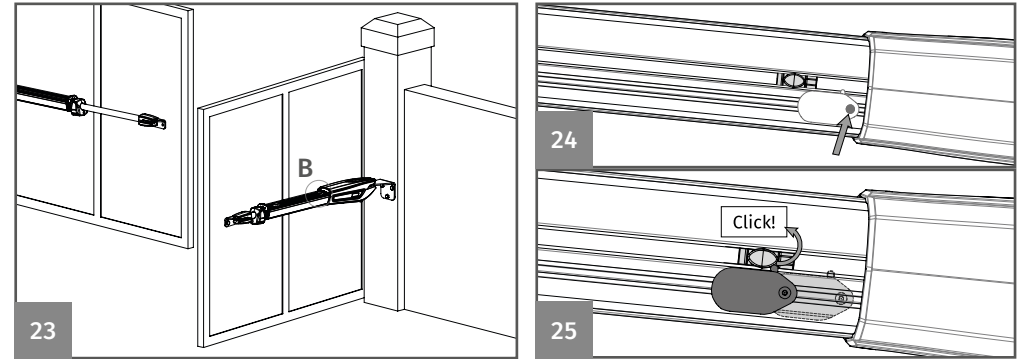

06 • Take the gate to the open position.

07 • Loosen the screw shown in the image (24), so that it is possible to move the micro-switch in the profile.

08 • Adjust the closure micro-switch (B) until it makes \*click\* on the pressure piece. Tighten the screw to secure the micro in that position.

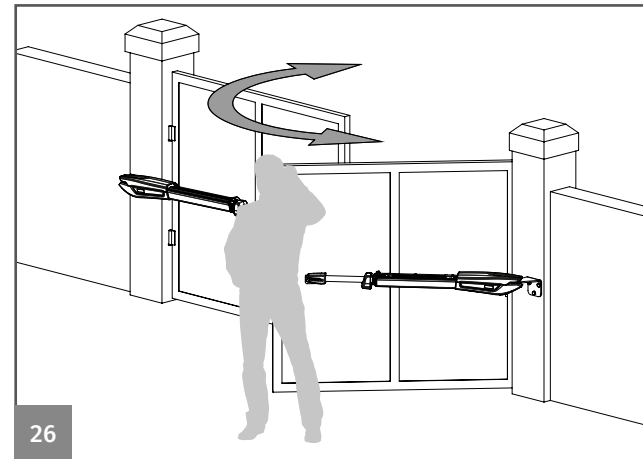

09 • Test the door manually and if necessary readjust the micros, as indicated in the previous paragraphs.

10 • When finished, place the profile cover and the plastic cover.

11 • Repeat the whole process for the other motor.

# 04. INSTALLATION

## INSTALLATION MAP

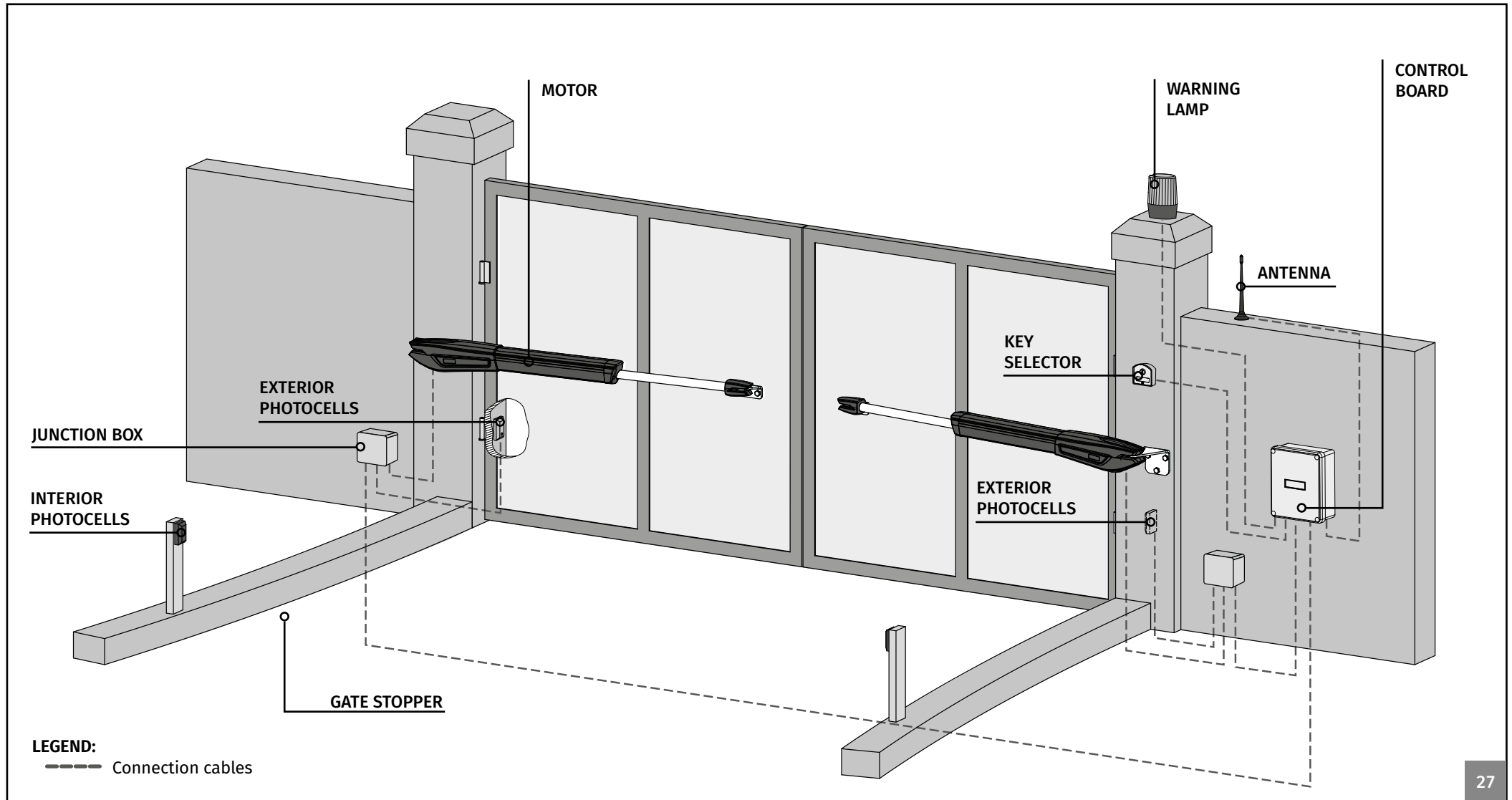

27



**It is important to use mechanical stoppers in the opening and closing position of the gate.** If not respected, components of the automation may suffer efforts for which they were not prepared, and as a result will be damaged.



**It is important to use junction boxes for connections between motors, components and control unit.** All cables must enter and exit on the bottom of the junction and control board box.



## 05. CONNECTION SCHEME

### 110V/230V MOTOR

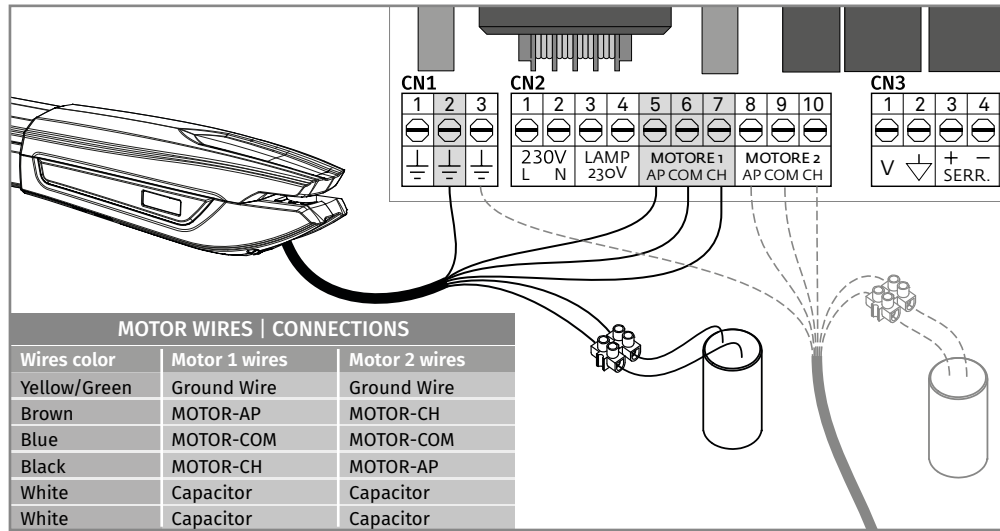

Connections should be made as shown above, connecting the 6 motor wires to the appropriate inputs of the central and capacitor.

**NOTE:** The white motor wires are connected directly to the capacitor wires!



- These connections correspond to an **installation with an opening to the interior**. If the automation is installed with an opening towards the **outside** of the gate, you **must swap the AP wire with the CH wire** on the motor 1 and 2.
- If the **motors work towards the opposite direction**, swap AP with CH.

### 24V MOTOR

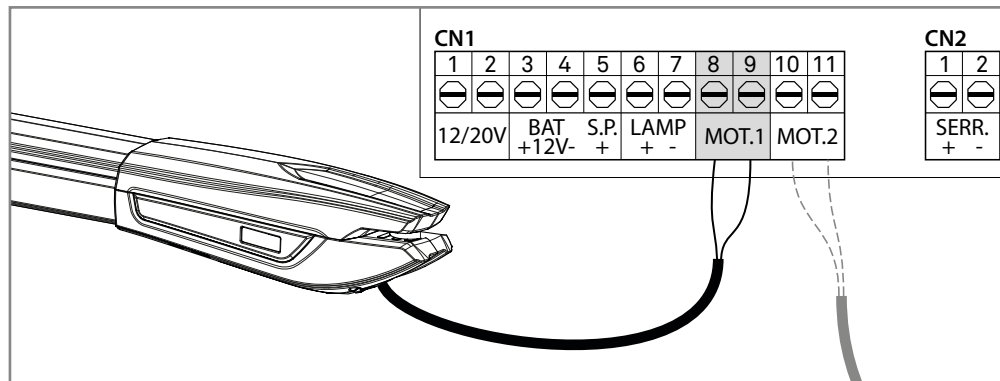

## 06. COMPONENTS TEST

### 24V MOTOR

To detect which are the components with problems in a 24V JAG automatism installation, it is necessary to conduct tests with a direct connection to an external power supply (bateria 24V). In the scheme below is shown how it should be done this link.

#### NOTES:

- Once you connect the wires to a 24V battery, the motor must work for one direction. To test the reverse movement, change the position of the wires connected to the battery.

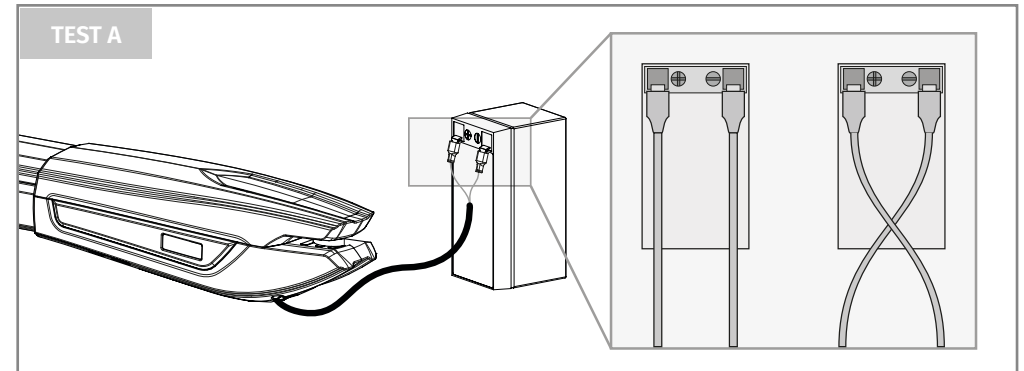

**Test A** • Make the connections as indicated in the image.

If the motor works, the problem is in the control board. If it does not operate, do the test B.

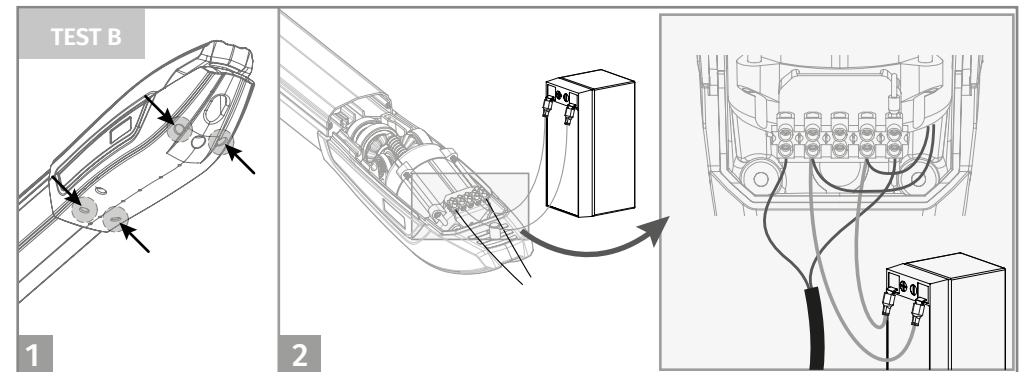

**Test B** • Loosen the 4 screws to remove the cover and access the internal connections.

Make the connections as indicated in the image.

If the motor works, the problem is on the diode(s) or on the micro(s). If it does not operate, replace with a new 24V engine and re-test to ensure that all is ok.

## 06. COMPONENTS TEST

### 230V/110V MOTOR

To detect if the malfunction is on the control board or on the motor is, sometimes, necessary to perform tests with connection directly to a 110V/230V power supply.

For this, it is necessary to interpose a capacitor on the connection in order to the automatism to work (check the type of capacitor to be used in the product manual).

The diagram below, shows how to make that connection and how to merge the different components wires.



All tests must be performed by qualified personnel due to serious danger associated with the misuse of electrical systems!!

#### NOTES:

- To perform the tests, there is no need to remove the automatism from the place it is installed, because in this way, it is possible to understand if the automatism can function properly connected directly to the current.
- You should use a new capacitor during this test to ensure that the problem does not lie on it.

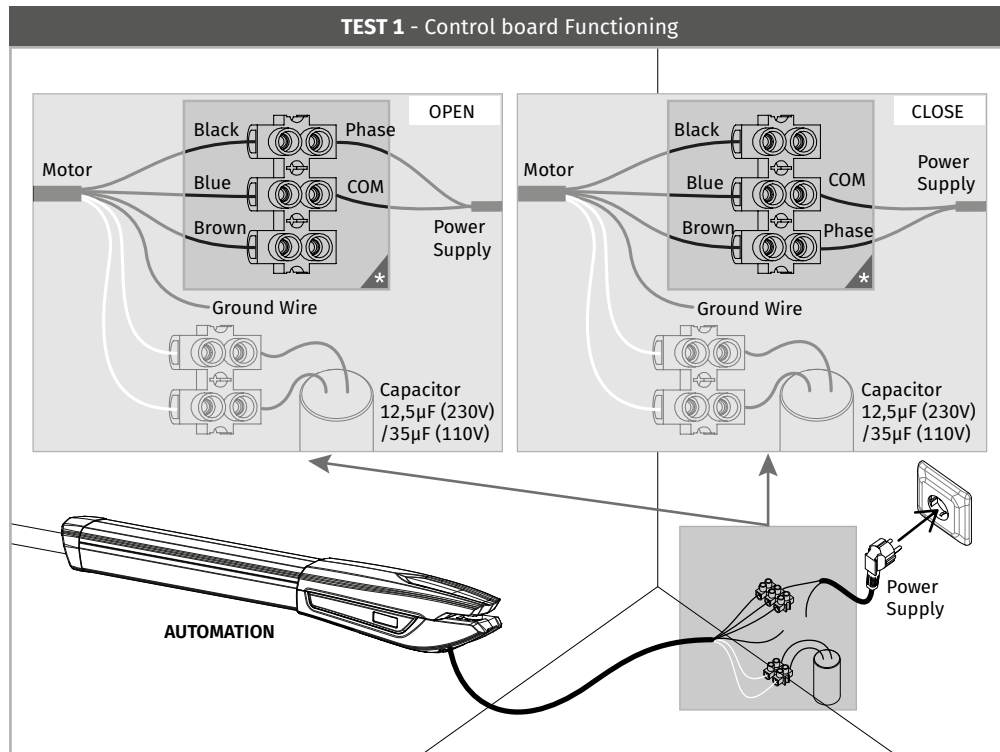

- 01 • Connect the 3 automation wires in the terminal.
  - 02 • Connect the two automation white wires with the capacitor wires.
  - 03 • Connect the power supply wires in the opening the motor will rotate one way and during the closing, the motor will rotate the opposite way.
  - 04 • Finally, connect it to a 230V or 110V plug, depending on the motor/control board in test.
- If the motor works**, the problem is in the control board.  
**If the motor does not**, make the **TEST 2**.

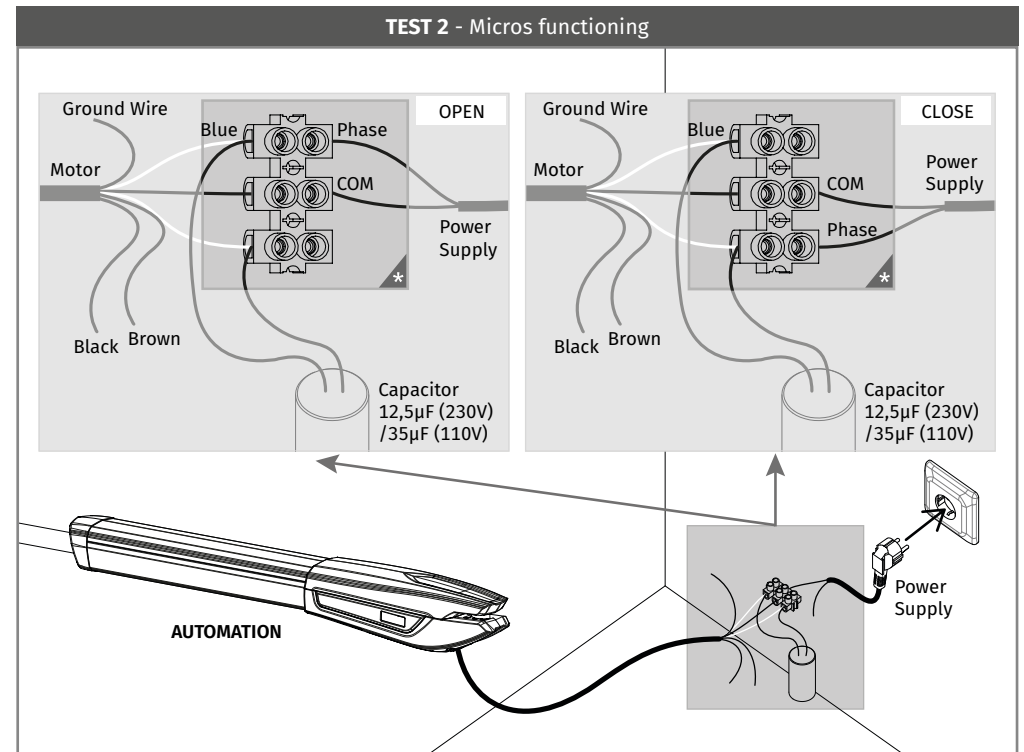

- 01 • Replace the brown and black wires by white wires and connect in the terminal.
  - 02 • Connect the capacitor in the terminal, in the same white wires inputs.
  - 03 • Connect the power supply wires in the opening the motor will rotate one way and during the closing, the motor will rotate the opposite way.
  - 04 • Finally, connect it to a 230V or 110V plug, depending on the motor/control board in test.
- If the motor works**, the problem is in the microswitches.  
**If the motor does not work**, normally the problem is on the motor. Replace it with a new one and test again.

## 07. MAINTENANCE

### MAINTENANCE

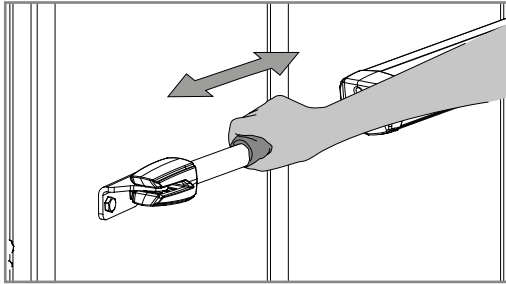

#### • Clean stainless steel arm

- With a cloth soaked in lubricant spray, wipe any residue that accumulates on the operator's stainless steel arm.
- Apply a small amount of spray lubricant on the arm and using a dry cloth remove the excess, leaving a homogeneous layer of lubricant over the arm.

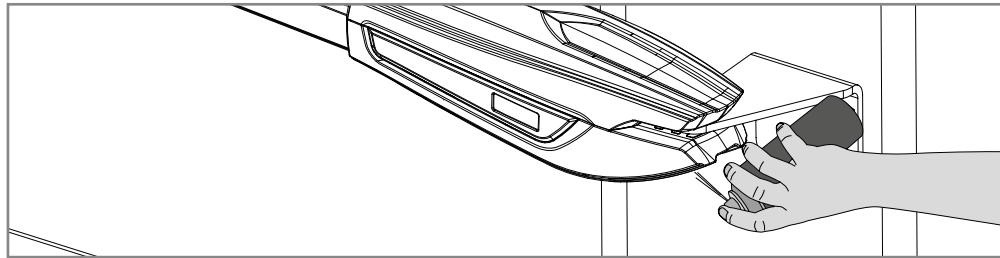

#### • Lubricate pins

- Place a small amount of lubricant on the holes that contains support pins.

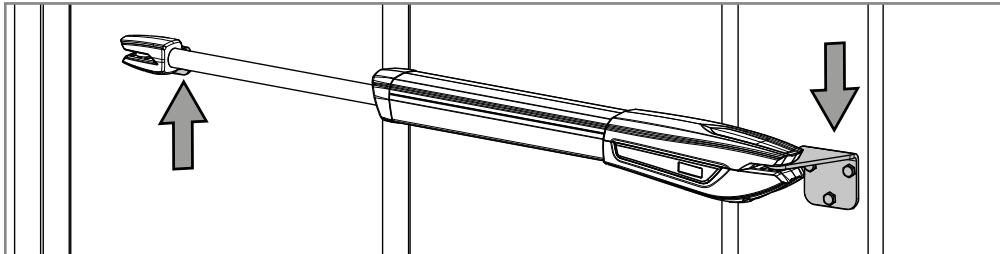

#### • Check motor supports

- Make sure that supports remain well fixed on the pillars and gate to ensure proper functioning of the equipment.



These maintenance measures must be applied every year in order to insure proper functioning of the automated system.

# 08. TROUBLESHOOTING

## FINAL CONSUMERS INSTRUCTIONS

## INSTRUCTIONS FOR SPECIALIZED INSTALLERS

Anomaly	Procedure	Behavior	Procedure II	Discovering the origin of the problem			
• Motor doesn't work at all.	• Make sure you have power in the automation control board and if it is working properly.	• Still not working.	• Consult a qualified MOTORLINE technician.	1 • Open control box and check if it has 230V/110V/24V power supply; 2 • Check input fuses; 3 • Disconnect motors from	control board and test them by connecting directly to power supply in order to find out if they have problems (see page 8B/9). 4 • If the motors work, the	problem is on the control board. Pull it out and send it to our MOTORLINE technical services for diagnosis; 5 • If the motors doesn't work,	remove them from installation site and send to our MOTORLINE technical services for diagnosis.
• Motor doesn't move but makes noise.	• Unlock motor and move gate by hand to check for mechanical problems on the gate.	• Is the gate closed?	• Consult an experienced gate expert.	1 • Check all motion axis and associated motion systems related with gate and operators (pins, hinges, etc.) to find out what is the problem.			
		• Gate moves easily?	• Consult a qualified MOTORLINE technician.	1 • Check capacitors, testing operator with new capacitors; 2 • If capacitors are not the problem, disconnect motors	from control board and test them by connecting directly to power supply in order to find out if they have problems (see page 8B/9).	3 • If the motors work, the problem is from control board. Pull it out and send it to our MOTORLINE technical services for diagnosis;	4 • If the motors doesn't work, remove them from installation site and send to our MOTORLINE technical services for diagnosis.
• Motor opens but doesn't close.	• Unlock motor and move gate by hand to closed position. Lock motor(s) again and turn off power supply for 5 seconds. Reconnect it and send order to open gate using transmitter.	• Gate opened but didn't close again.	1 • Check if there is any obstacle in front of the photocells; 2 • Check if any of the control devices (key selector, push button, video intercom, etc.) of the gate are jammed and sending permanent signal to control unit; 3 • Consult a qualified MOTORLINE technician.	All MOTORLINE control boards have LEDs that easily allow to conclude which devices are with anomalies. All safety devices LEDs (DS) in normal situations remain On. All "START" circuits LEDs in normal situations remain Off. If LEDs devices are not all On, there is some security systems malfunction (photocells, safety edges), etc. If "START" circuits LEDs are turn On, there is a control device sending permanent signal.	<b>A) SECURITY SYSTEMS:</b> 1 • Close with a shunt all safety systems on the control board (check manual of the control board in question). If the automated system starts working normally check for the problematic device. 2 • Remove one shunt at a time until you find the malfunction device . 3 • Replace it for a functional device and check if the operator works correctly with all the other devices. If you find another one defective, follow the same steps until you find all the problems.	<b>B) START SYSTEMS:</b> 1 • Disconnect all wires from START terminal input. 2 • If the LED turned Off, try reconnecting one device at a time until you find the defective device.  <b>NOTE:</b> In case procedures described in sections A) and B) don't result, remove control board and send to our technical services for diagnosis.	
• Motor doesn't make complete route.	• Unlock motor and move gate by hand to check for mechanical problems on the gate.	• Encountered problems?	• Consult an experienced gate expert.	1 • Check all motion axis and associated motion systems related with gate and operators (pins, hinges, etc.) to find out what is the problem.			
		• Gate moves easily?	• Consult a qualified MOTORLINE technician.	1 • Check capacitors, testing with new capacitors; 2 • If capacitors are not the problem, disconnect motors from control board and test them by connecting directly to power supply in order to find out if they are faulty; 3 • If the motors doesn't work, remove them from installation site and send to our MOTORLINE technical services for diagnosis.	4 • If motors work well and move gate at full force during the entire course, the problem is from controller. Set force using trimmer on the board. Make a new working time programming , giving sufficient time for opening and closing with appropriate force (see manual of the controller in question). 5 • If this doesn't work, remove control unit and send it to	MOTORLINE technical services	<b>NOTE:</b> Setting force of the controller should be sufficient to make the gate open and close without stopping, but should stop with a little effort from a person. In case of safety systems failure, the gate shall never cause physical damaged to obstacles (vehicles, people, etc.).